

Model: X-173
Rugged 17.3" Notebook



Specification

Product Model	IX-173
Processor	Intel Core i7 4770
Chipset	Intel H81
Display	17.3" Full HD LED Display, screen resolution @ 1920 x 1080
RAM	2 x DDRIII 8G (Optional upgrade to 32GB)
Storage	2.5" 250G SSD
IO Interface	DVIx1, HDMIx1, RS232x2, USB3.0x2, USB2.0x2
Expansion Slot	1 x PCI-E X16; 1 x Mini PCI-E
Keyboard	Splash Waterproof keyboard with touchpad
Audio	Realtek ALC887 Audio Codec
Communication	Wifi 802.11 a/b/g/n, Gigabit Lanx2, Bluetooth 4.0, GPS
Power Adapter	AC110-240V
Battery	Smart lithium battery 7800mAH, with battery management software
Cooling	Fan cooling
Dimension	436mm(W) x 300mm(D) x 120mm(H)

Structure Diagram

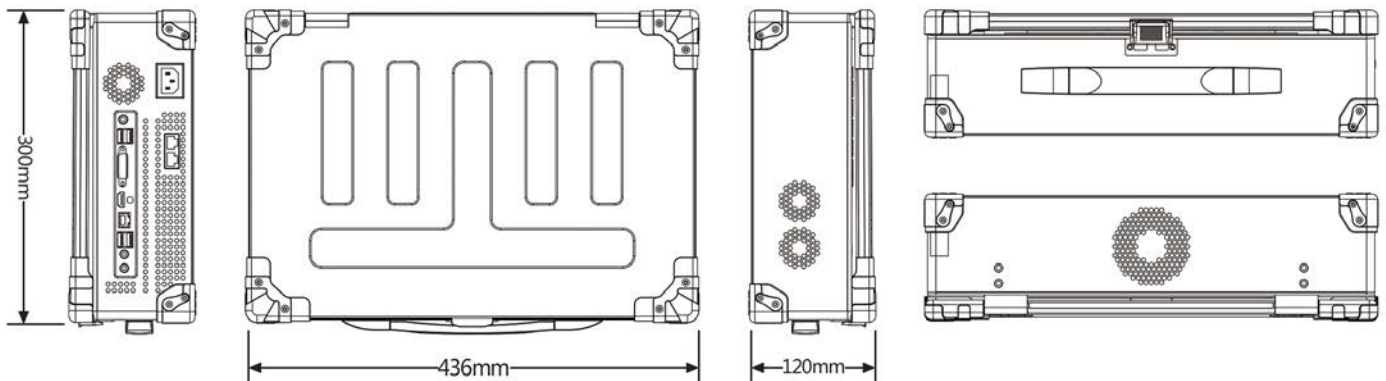

All specifications are subject to change without prior notice