

Model: X-156
Rugged 15.6" Notebook



Specification

Product Model	IX-156
Processor	Intel Core i7 3610QM
Chipset	Intel QM77
Display	15.6" LED Display, screen resolution @ 1366x768 (Optional upgrade to Full HD)
RAM	DDRIII 8G (Optional upgrade to 16GB)
Storage	2.5" 250G SSD
IO Interface	VGAX1, HDMIx1, RS232x2, USB3.0x2, USB2.0x2
Expansion Slot	1 x PCI-E X16; 1 x Mini PCI-E
Keyboard	Splash Waterproof keyboard with touchpad
Audio	Realtek ALC887 Audio Codec
Communication	Wifi 802.11 a/b/g/n, Gigabit Lanx2, Bluetooth 4.0, GPS
Power Adapter	Input: AC110-240V, Output: DC19V 150W
Battery	Smart lithium battery 7800mAH, with battery management software
Cooling	Fan cooling
Dimension	396mm(W) x 276mm(D) x 112mm(H)

Structure Diagram

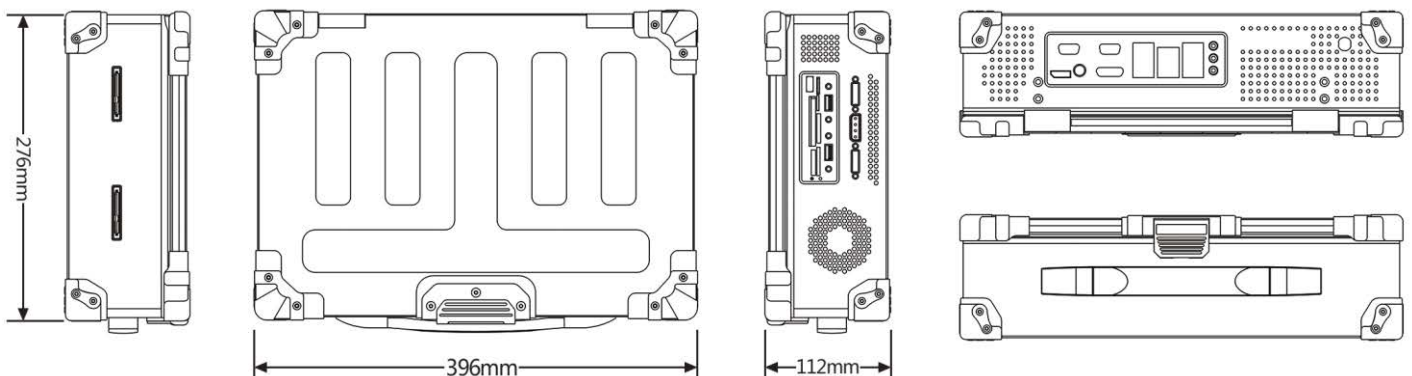

All specifications are subject to change without prior notice