

Model: MIPM-17
17" Marine Industrial Panel Monitor (VGA +DVI + S-Video + AV input)

Main Feature

- Dimming knob control backlight from nearly 0% to 100%
- Front IP65 aluminum bezel with powder coating
- Wide range DC8-30V power input with Lockable connector (AC Power in option)
- Front hardness AR glass protection (touch option)
- Build in 2 x 2 watts stereo speaker
- IP65 Front OSD Design, Ease for use front OSD control
- Enhanced anti-shock and vibration resistance design
- Meet standard VESA hole (75 x 75mm and 100 x 100mm)
- Panel (Flush) mount, VESA and bracket mount



Specification	
Product Model	MIPM-17
LCD Panel	Display Type : 17" SXGA TFT LCD Screen resolution (Pixels) : 1280 × 1024 Brightness : 300cd/m2 Contrast Ratio : 1000 : 1 Pixel Size : 0.264*0.264 Max Color : 16.7MB Viewing angle : 178° (H) , 178° (V) Response Time : 5 ms LCD MTBF : 50,000hrs
Mechanical and Environmental	Power Control : Front Power On/Off via Front Button OSD control : Front on screen display control Mounting : Panel (Flush) mount ,VESA and bracket mount Dimensions (WxHxD) : 408 x 345 x 55 mm Weight : Net 8kg Operating Temperature : 0 °C to 50 °C Storage temperature : -20 °C to 60 °C Storage humidity : 10% to 90%non-condensing Anti-Vibration : 5Hz-500 HZ / 1G PTP Anti-Shock : 15G / Peak(11m sec)
Available Options	AC Power input : 100 to 240 V AC Bracket mount : Stand and roof mount / Rotary bracket / Sun Visor bracket
Input Signals	RGB Signal : D-SUB 15P connector(female) Composite Audio/Video : RCA plug S-Video Signal : S-Video (SVHS) plug DVI-D Signal : DVI-D input 24pin connector DC Power Signal : 5.8mm DC Jack with Lockable AC Power Signal (Option) : Standard IEC Inlet
Power Specifications	DC Input : 8-30V DC to DC power input with Lockable connector
Certification and Approvals	CE/FCC/Rohs Certification: IEC60945

Ordering Information

MIPM-17	17" Marine Industrial Panel Monitor (VGA +DVI + S-Video + AV input)
Optional: SR-BKT	Mounting bracket for stand and roof mount
Optional: RT-BKT	Rotary bracket
Optional: SV-BKT	Sun Visor bracket

Mechanical Drawing with Robust Bracket (options)

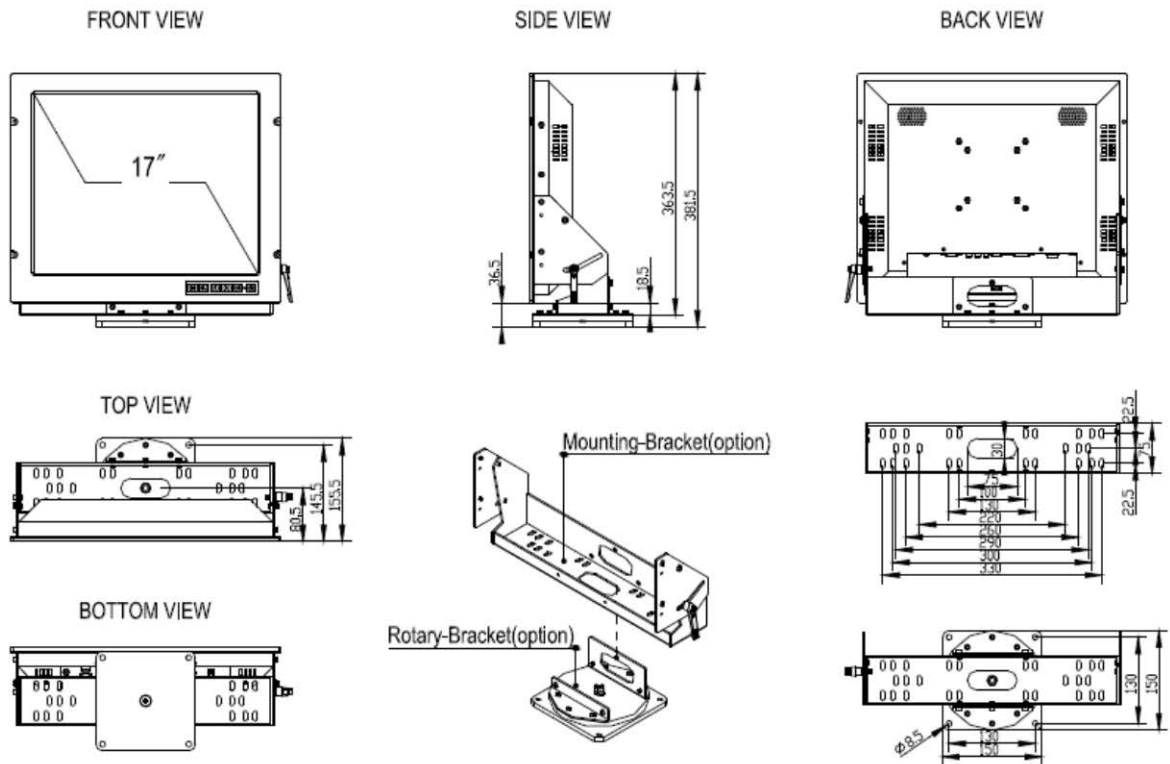

STAND MOUNT Bracket

Unit :mm

