

Model: KVM-1703W-COMBO

2U Triple Display Console Drawer, with keyboard + Touch-pad

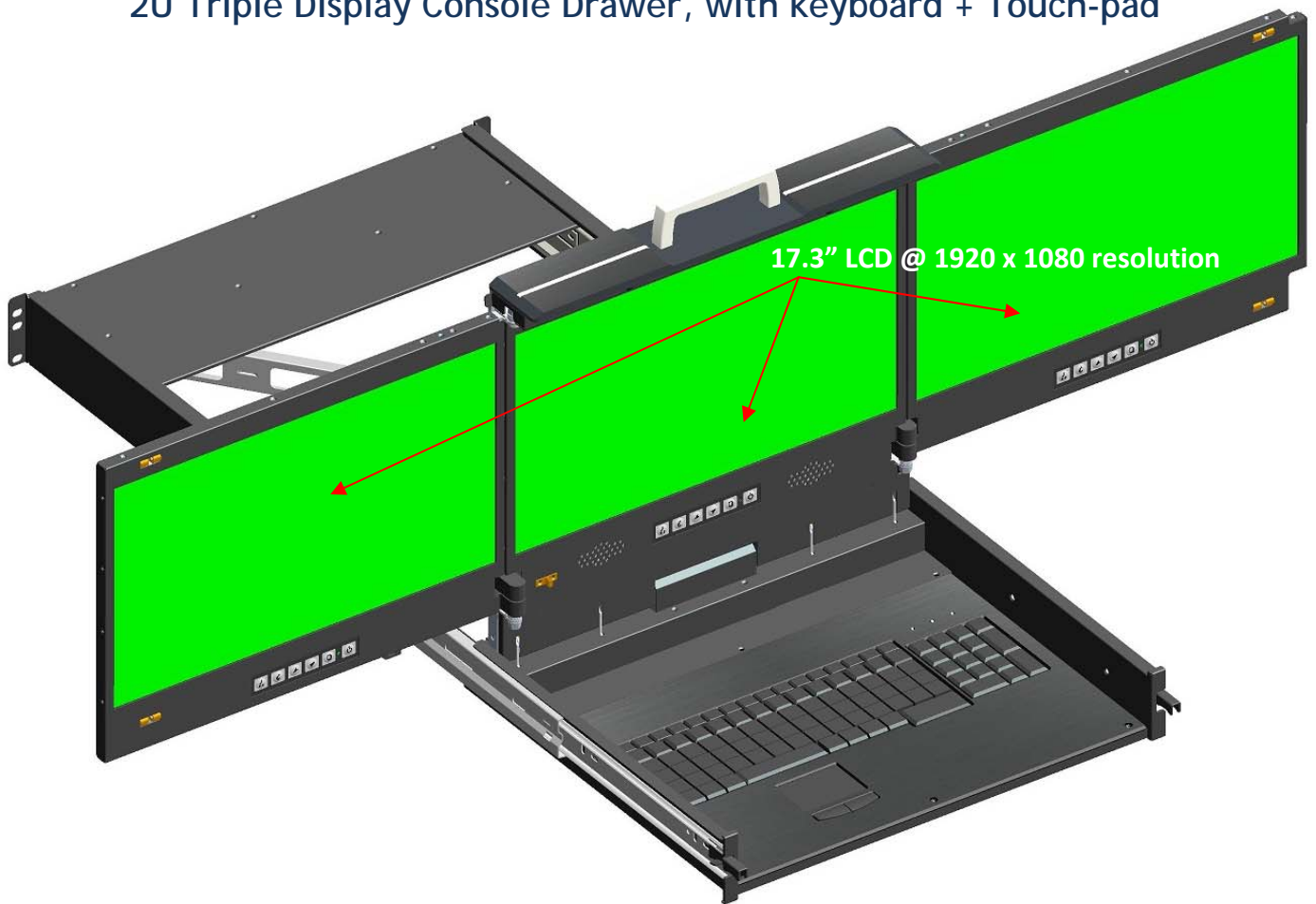

### Rear View

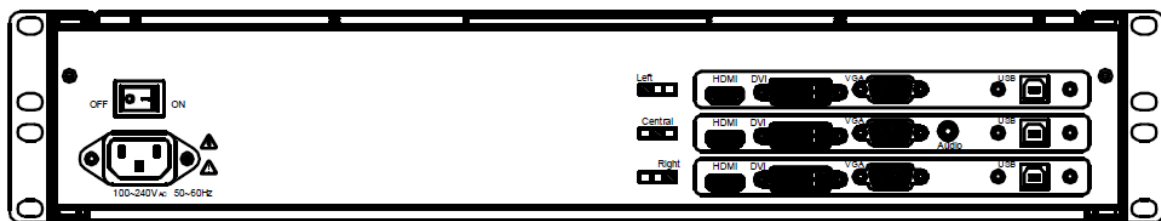

### Main Feature

- 2U 19'' rackmount drawer integrated keyboard drawer and 3 x 17.3" Full HD LED Monitor
- Rugged construction for mobility & durability
- 3 x VGA + DVI + HDMI input, viewing 3 x monitors simultaneously
- Each monitor has an independent OSD control, allowing independent panel control
- Hot-Key to select Keyboard & Touch-pad between 3 x computers
- 104 keys keyboard with touchpad
- Support DOS, Windows, Netware, Unix, Linux, Mac OS
- Hot Pluggable - Add or remove connected PCs without having to power down the computers
- Superior video quality @ 1920 x 1080, up to 1920 x 1200
- Build-in 2x 2 Watts stereo speaker
- No software required
- Auto Scan Mode for monitoring PCs

Specification		
Product Model		KVM-1703W-COMBO
LCD	Size	3 x 17.3" Full HD LED Panel
	Resolution	1920 x 1080
	Max. color	26.2M
	Luminance	300 cd/m2
	View Angel	140°(H) , 120°(V)
	Pixel Pitch	0.1989 x 0.1989 mm
	Contrast Ratio	500 : 1
Host Port Connection		3 x VGA / DVI-D / HDMI Port female 3 x USB Port (for keyboard & touch-pad) 1 x Audio Port 3.5mm phone Jack
Internal Power Adapter		100-240VAC; 50/60Hz; 12VDC/5A , 60w via IEC type cord
Environment	Operating Temperature	0-50°C
	Store Temperature	-20-60°C
	Humidity	10-90% RH , NC
Housing		Heavy Duty Steel
Size		2U 19" Rack mount type
Rack Installation Depth		600 to 900mm (front to rear rails)
Net / Gross Weight		18kg / 21kg
Dimensions (W*D*H)		450 x 535 x 88 mm
Order Information		
KVM-1703W-COMBO		2U Triple Display Console Drawer , with keyboard + Touch-pad, 1.5 meter of 3 x VGA / DVI / HDMI, 3 x USB, 1 x Audio cable
Optional		Upgrade to 8-30VDC input

## Structure Diagram Unit :mm

