

# 15.6 " Full HD Portable LCD Console

KVM-156WHD

**NORCO SEA**  
PTE LTD

## Features

- 15.6" Full HD TFT LED Panel support 1920 x 1080 pixels
- Aluminum Case, Portable and Light weight for easy handheld
- Rugged construction and slim modularized design
- Input signal: VGA + HDMI
- 250 cd/m2 brightness
- Front 2 x USB2.0 Type A, Sharing USB peripheral Device for computer (ex, flash disk, hard driver, KB / Mouse)
- Durable 96-key keyboard and touch pad.
- Hot Pluggable, no software or driver required.
- DC 12V Input

## Design Drawings

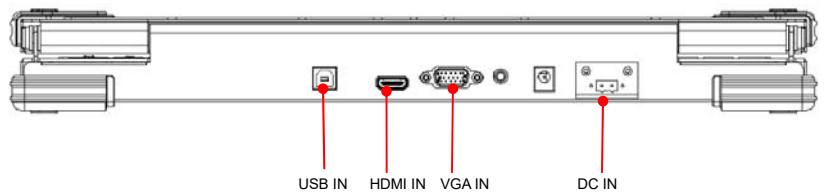

## Specifications

### TFT characteristics

Display Type : 15.6" Full HD TFT LCD  
Resolution : 1920 x 1080  
Max.color : 16.7M  
Luminance : 250 cd/m2  
View Angle : 178° (H) , 178° (V)  
Pixel Pitch : 59.75 x 179.25 um  
Contrast Ratio : 3000 : 1  
Response Time : 15 ms  
LCD MTBF : 50,000hrs

### Mechanical and Environmental

Construction : All-aluminum material  
Dimensions (WxHxD) : 395 x 295 x 50.3 mm  
Weight : Net: 3.5kg , Gross:6.0 kg  
Operating temperature : 0 °C to 50 °C  
Storage temperature : -20 °C to 60 °C  
Storage humidity : 10% to 90% non-condensing  
Anti-Vibration : 17HZ-500 HZ 1G PTP  
Anti-Shock : 1G / peak( 11m sec)

### Available Options

Touch Screen : Resistive Type with USB and RS232 controller  
DC Power Input : wide Range 9~36v DC input

### Power Specifications

Input: 100~240VAC,50/60Hz  
Output: DC12V@ 5A / 60W ,external ac adapter

### Input Signals

RGB Signal : D-SUB 15P Connector (female)  
DC input : 2Pin Terminal Blocks  
HDMI Signal : HDMI input connector (female)  
Touch screen RS232 (option) : D-SUB 9p connector (female)  
Touch screen USB (option) : USB-A type connector (female)

# 15.6 " Full HD Portable LCD Console

KVM-156WHD



## Certification and Approvals

• CE/FCC/ROHS

## Ordering Information

### Product Model:

KVM-156WHD: 15.6" Full HD portable LCD Console, with VGA + HDMI input

KVM-156WHD-T: 15.6" Full HD portable LCD Console, with VGA + HDMI input, with touch screen - USB interface

DC: add Wide Range 12 ~ 24VDC input power module

## Accessory

Power Adapter x 1, 1.5meter IEC Type Power Cord x1 , 1.5 meter VGA cable x 1 , 1.5 meter HDMI cable x 1 , 1.5meter USB cable x 1

## Design Drawings

Unit : mm

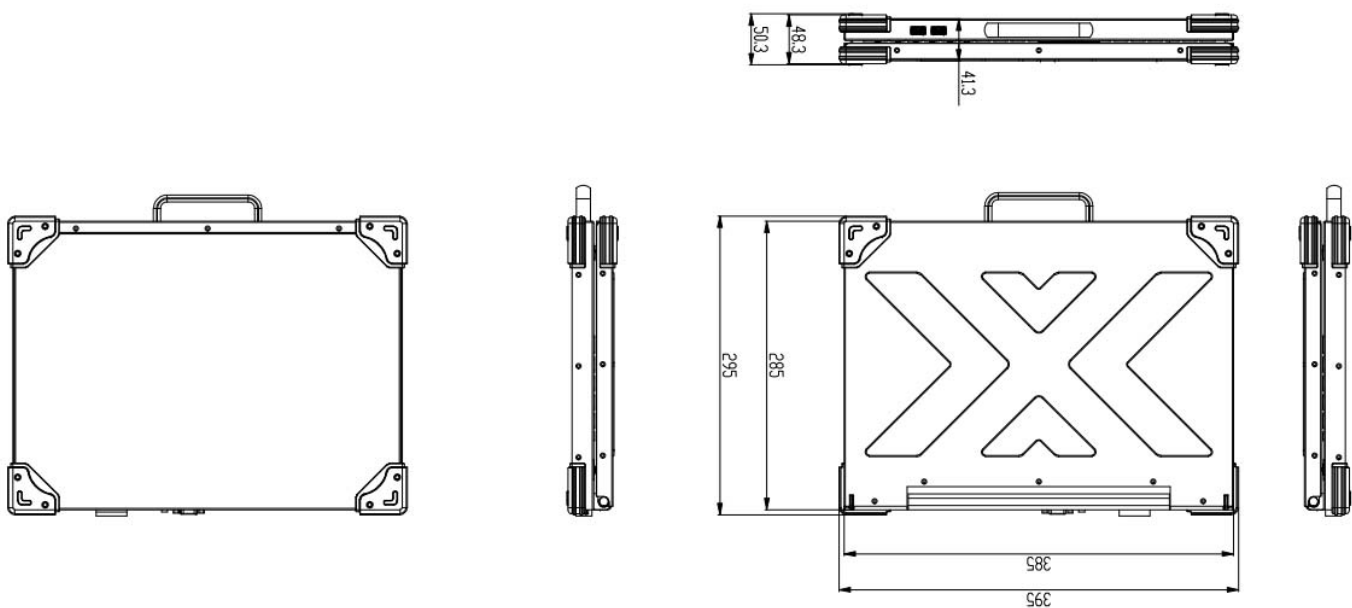

NORCO S.E.A. PTE LTD  
GST Registration No.: 200901437Z

Tel: (65) 6853 0809  
20 Woodlands Link, #09-23, Woodland East Ind' Estate, Singapore 738733

Fax: (65) 6853 0153

Company Registration No.: 200901437Z  
Website: www.sg-norco.com

All specifications are subject to change without prior notice