

Model: IDPMB-42WHD
42" Industrial Panel Monitor (Wide Screen)

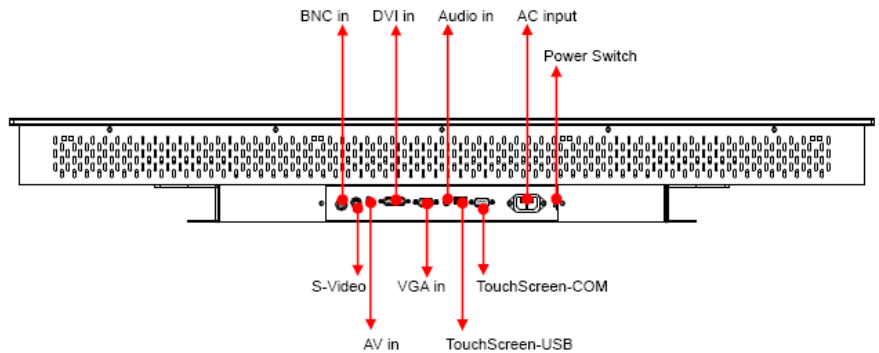
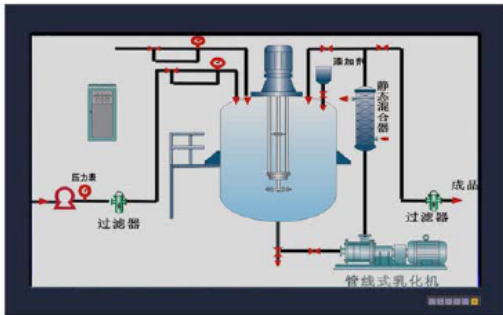

Main Feature

- 42" Full HD TFT LCD Panel support 1920 × 1080 pixels
- 6mm Aluminum front bezel with strengthen glass
- Rugged construction design
- Input signal : VGA + DVI + Audio
- Build in 2 x 8 Watts stereo speaker
- OSD control keys to optimize the display
- IP 42 compliant front panel
- AC 100-240V wide range power input
- Panel mounting with clip, and wall mount bracket included
- Meet standard VESA hole (75x75 and 100x100 mm)

Specification	
Product Model	IDPMB-42WHD
LCD Panel	Display Type : 42" Full HD TFT LCD Resolution : 1920 x 1080 Max. color : 16.7M Luminance : 500 cd/m2 View Angel : 178° (H), 178° (V) Pixel Pitch : 0.4845 x 0.4845 mm Contrast Ratio : 1500 : 1 Response Time : 20 ms Power Consumption : 187 Watt LCD MTBF : 60,000hrs
Signal Input	VGA (15 pin D-sub connector) + DVI (DVI-D) + audio input (audio jack)
Protect Glass	3 mm strengthen glass
Speaker	Built-in 2x stereo speakers(8 watt)
OSD	Brightness, Contrast, H/V Position, Color, Phase, Clock, PIP, Auto tune and recall
Signal Connectivity (optional)	AV input (S-Video, RCA, BNC)
Power Supply	Input: 100~240VAC,50/60Hz, with 300 Watt internal power board

Construction	Heavy duty steel and aluminum front panel
Environment	Operating temperature: 0 °C to 50 °C Storage temperature: -20 °C to 60 °C Storage humidity: 10% to 95%, non-condensing Vibration: 17 to 500HZ 1G PTP Shock: 1G /peak(11m sec)
Safety	CE/FCC/Rohs
Dimension W x H x D (mm)	Dimensions: 1040x650x124.8 mm

Ordering Information

IDPMB-42WHD	42" Industrial Panel Monitor (Wide Screen)
Optional: AV	Support AV Input (S-Video, RCA, BNC)

Structure Diagram Unit: mm

