

Model: FPM-7319T
19" Industrial Monitor - Projected Capacitive Touch screen, VGA and HDMI inputs



Main Feature

- LED Panel - Higher Brightness; Longer Life Span; Better Viewing Angle; Less Power Consumption ...
- 19" SXGA LED Panel support 1280x1024 pixels
- 8mm Aluminum Magnesium Alloy front bezel
- NEMA4 / IP 65 compliant front panel, with Rugged construction design
- Front flat glass (7H Hardness) with projected capacitive Multi Touch Screen
- Supports 10 points multi-touch via USB interface in Windows 7/8.1/10...
- Slim design for Panel mount / Wall mount easy installation
- Input signal : VGA + HDMI + USB
- Wide Range 12-24VDC input
- Meet standard VESA hole (75x75 & 100X100mm), support desktop stand/wall mount /swing arm mounting

Application:

Factory Automation, Processor Automation, Power Generation, Marine / Offshore Industrial, Kiosk ...

Specification	
Product Model	FPM-7319T
LCD Panel	Display Type : 19" SXGA <u>LED Panel</u> Resolution : 1280x1024 Max. color : 16.7M Luminance : 250 nit View Angel : 170°(H), 160°(V) Contrast Ratio : 1000 : 1 LED backlight lifecycle : 50,000hrs
Signal Input	VGA + HDMI + USB
OSD	Auto; Menu; Left; Right; Exit/Select; Power On/Off
Touch Screen	Internal USB interface controller - Projected Capacitive Multi Touch (10 points) Light transmission: 85% or more Surface hardness : 7H Operation system : DOS; Windows XP / 7 / 8.1 / 10; Linux
Power Supply	Input: 12-24VDC Wide range

Construction	Aluminum magnesium alloy front panel with heavy-duty steel chassis
Environment	Operating temperature: -0 °C to 60 °C Storage temperature: -20 °C to 70 °C Storage humidity: 10% to 95%, non-condensing Vibration: 50 to 500HZ 1G PTP Shock: 10G /peak(11m sec)
Safety	CE/FCC/Rohs
Dimension W x H x D (mm)	460 x 369 x 47 mm

Ordering Information

FPM-7319T	19" Industrial Monitor with Projected Capacitive Touch screen , VGA + HDMI input
(Optional) AC to DC Adapter	12VDC/60watt Power Adapter, input 110-240VAC

Structure Diagram (Panel cut-off dimension: 442 x 352mm)

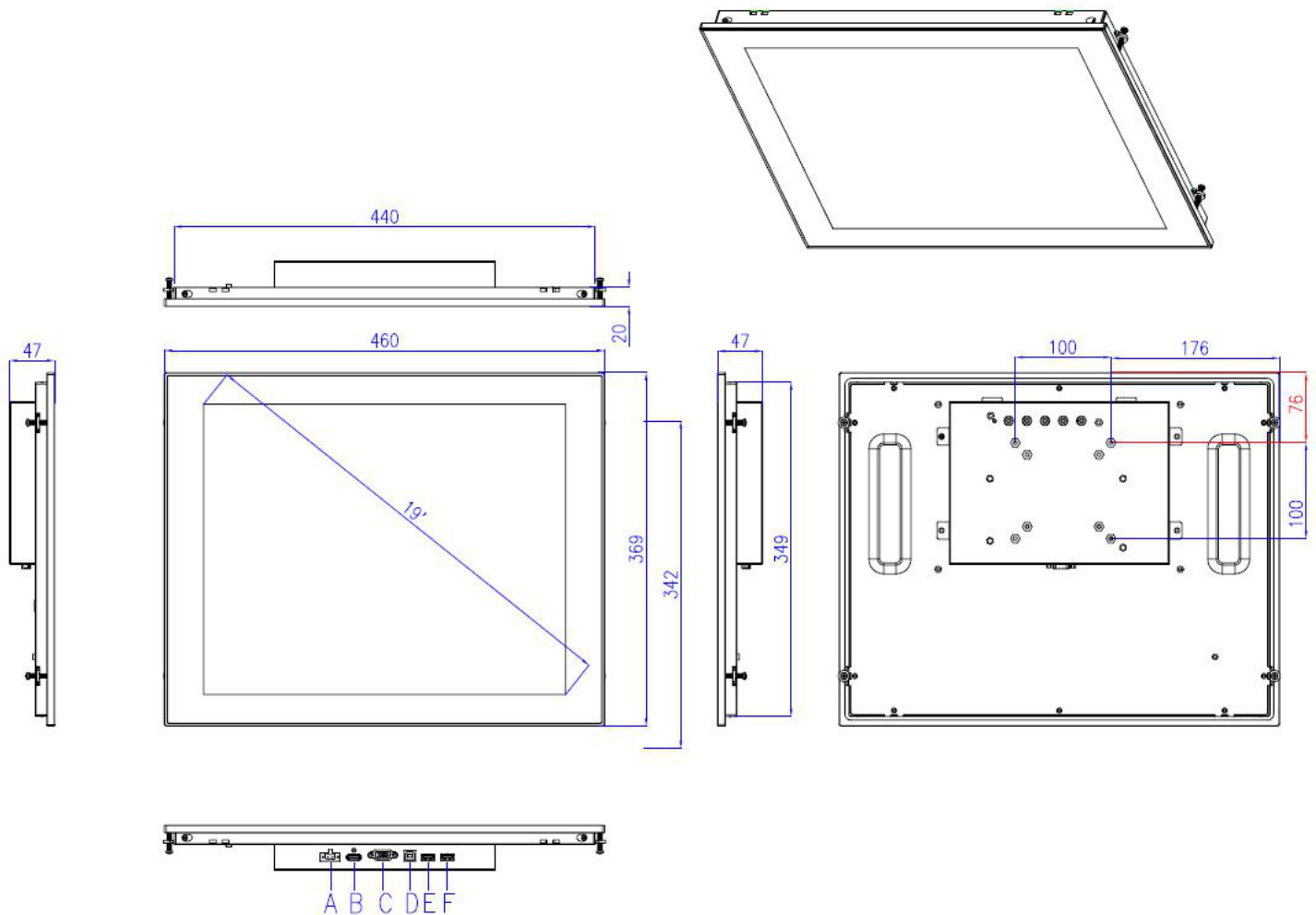

A: DC Input B: HDMI C: VGA
D: USB for Touch E: USB F: USB