

Product Model: ARM-405
LCD Monitor / TV Wall Mount Swivel Arm

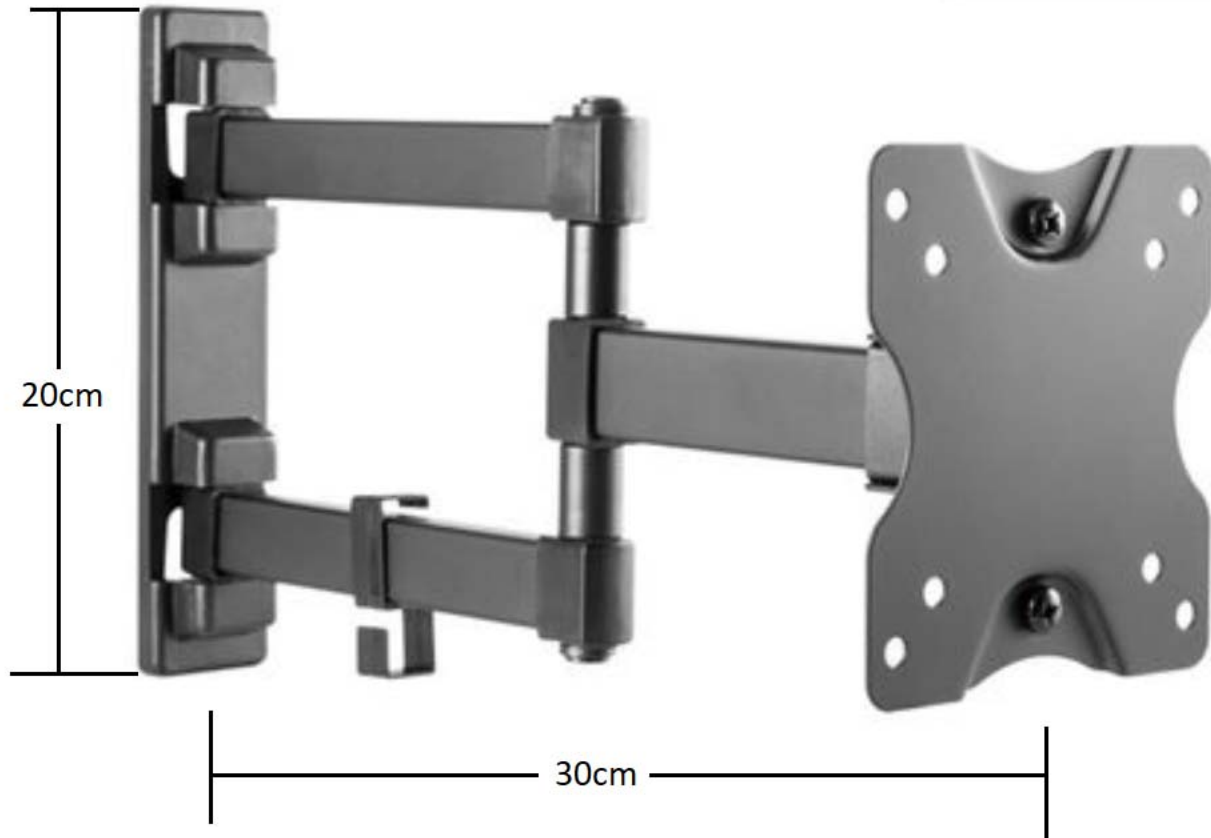

- Workspace saver
- Superior flexibility and movement
- Fast and easy to install
- Material: Harden Steel

Feature:

- Panel to wall distance: 35cm
- Standard VESA Mounting Hole (75x75mm & 100x100mm)
- For LCD Monitor & Panel PC up to 27"
- Maximum loading weight 20kg